

# MOVAX

SPH-80DB  
SPH-75DB

## SIDE-GRIP



*From 22 to 30 ton*

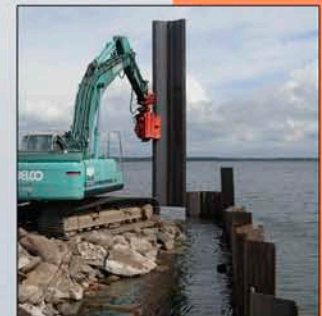
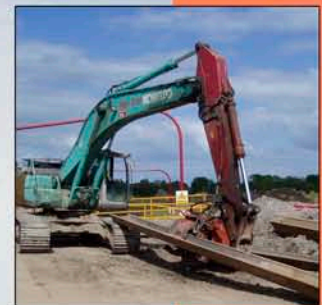

### SPH-80 and SPH-75

Four shaft vibra construction, directional hitting and heavy duty design makes the SPH-80 an efficient sheet piler.

Directional hitting reduces ground vibration to a lower level than in the same size conventional vibratory driver.

Needed oil flow of 240 liters/ min at 280 bar and weight of 2400 kg requires a 35 t excavator.

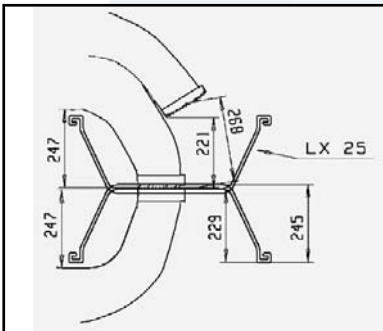

#### Suitable sheet piles

Piler type	SPH-75DB / SPH-80DB
<b>Sheet piles</b>	
- Width of the pile (mm)	600-1200
- "Depth" of the pile (mm)	230
- Weight of the pile (kg) length over / under 8 m	1400 / 2200
<b>H-beams</b>	
- Min. size	H240
<b>Tubes</b> (Needs optional pipe clamps which are fitted to sheet piler's jaws)	
- Sizes	Ø220, Ø200, Ø190, Ø170, Ø140, Ø115, Ø90 (individual for each Piler type)

#### Technical data

Piler type	SPH-75DB	SPH-80DB
Weight without adapter (kg)	2400	
Height (mm)	2284	
Depth (mm)	1259	
Width (mm)	1128	
Excavator class (ton)	30-34	25-40 3)
Oil flow (l/min)	220 2)	240 2)
Max. return pressure (bar)	5	
Pressure setting (bar)	320	
Frequency (1/min)	2-speed vibr.	
Centrifugal force (kN)	750	800
Driving method	vibra	
Swing / tilt angle (o)	360/30	
Number of arms	3 + 1	
Oil pump (lubrication)	Yes	
2) Oil flow at 280 bar only I-pump installation allowed		
3) 25-30 ton excavator equipped with Movax power-pack		